

# Madrid

Design by BoConcept

Samvejledning - Assembly Instructions - Montageanleitung - Instructions d'assemblage - Instrucciones de montaje

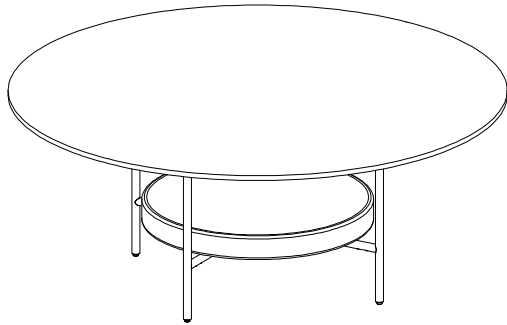

**AD24 and AD26**  
1830/1670 And 1830/1690  
40 x 99/80 x 99/80 cm  
Max weight 15 KG

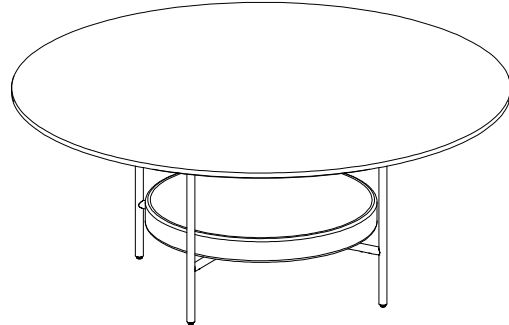

**AD25 and AD27**  
1830/1700 and 1830/1710  
40 x 99/80 x 99/80 cm  
Max weight 15 KG

Korpus - Korpus - Carcase - Carcasse  
Col. 1832

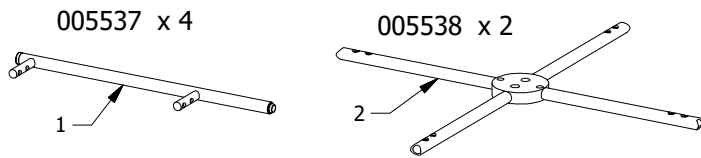

Korpus - Korpus - Carcase - Carcasse  
Col. 1831

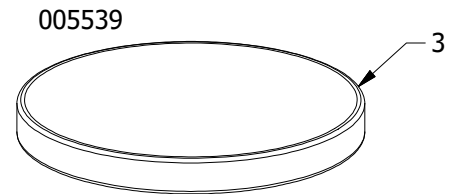

Beslag - Beschlage - Fittings - Set de montage Col. 1832  
937000076



Spare part bag  
937000079

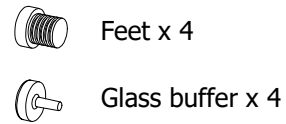
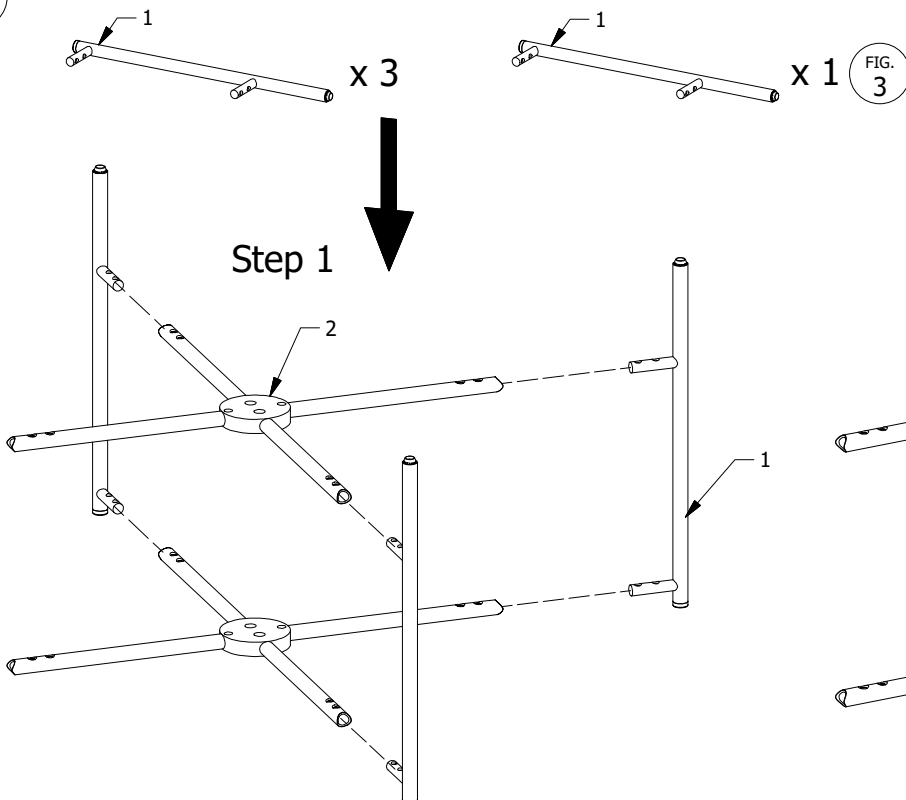

FIG. 1



A x 12

Step 2

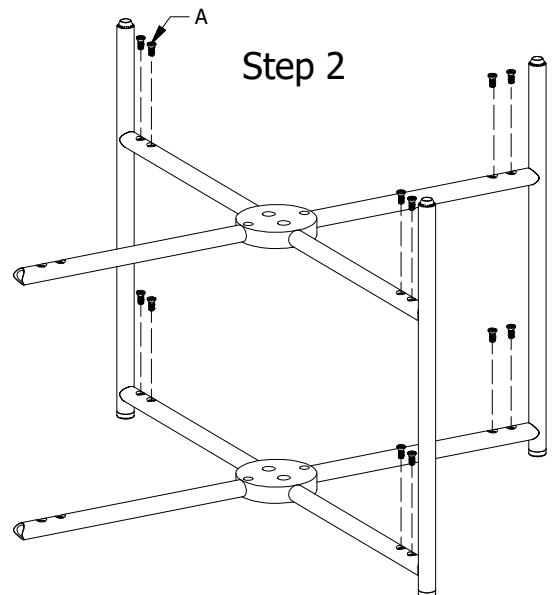
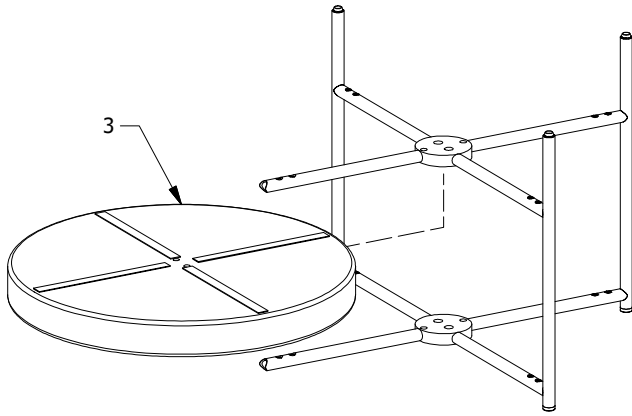
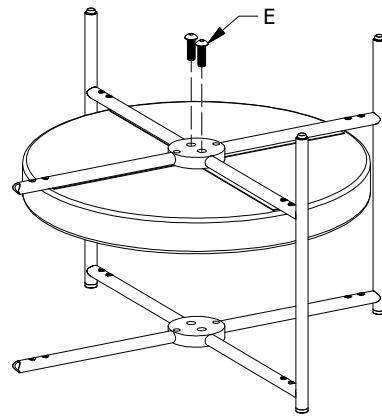

FIG. 2

Step 1



Step 2



  
E x 2  
30 mm

FIG. 3



  
A x 4

FIG. 4

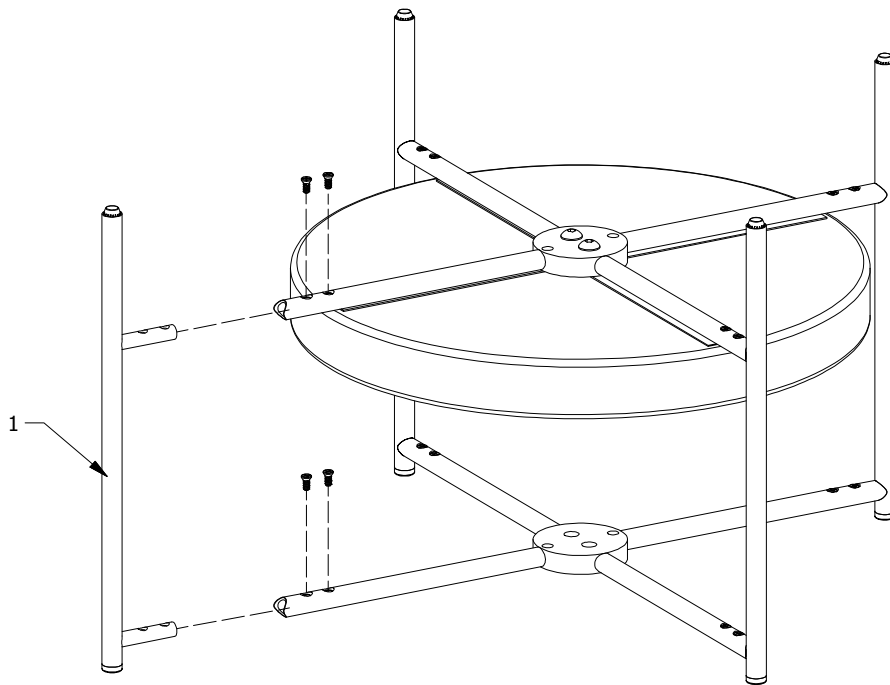

1830/1670 And 1830/1690  
Max weight 15 KG

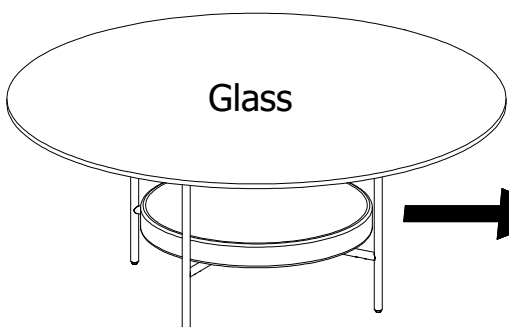
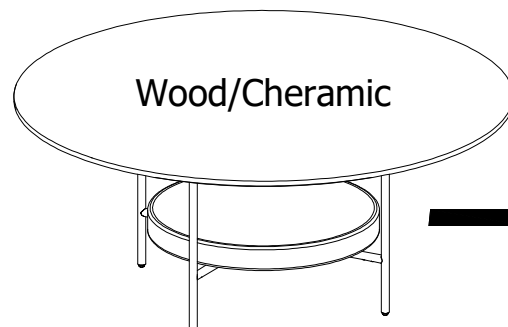

1830/1700 and 1830/1710  
Max weight 15 KG

FIG. 5

FIG. 6

FIG. 5

  
B x 2  
22 mm

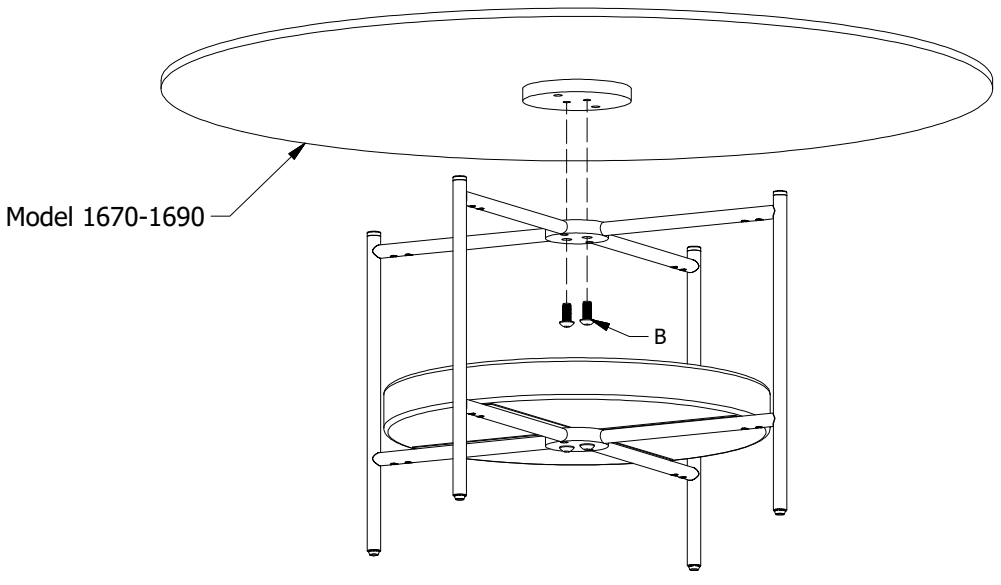

FIG. 6

Model 370-1700, 370-1710

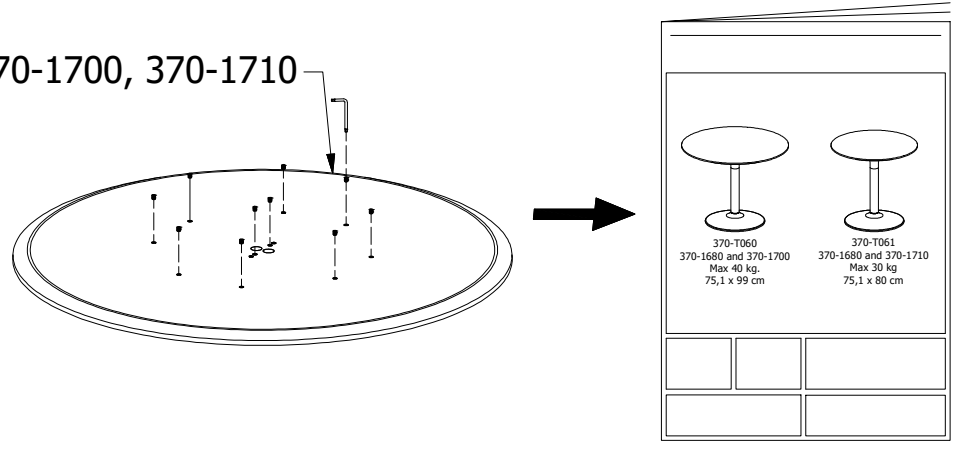

FIG. 1

FIG. 7

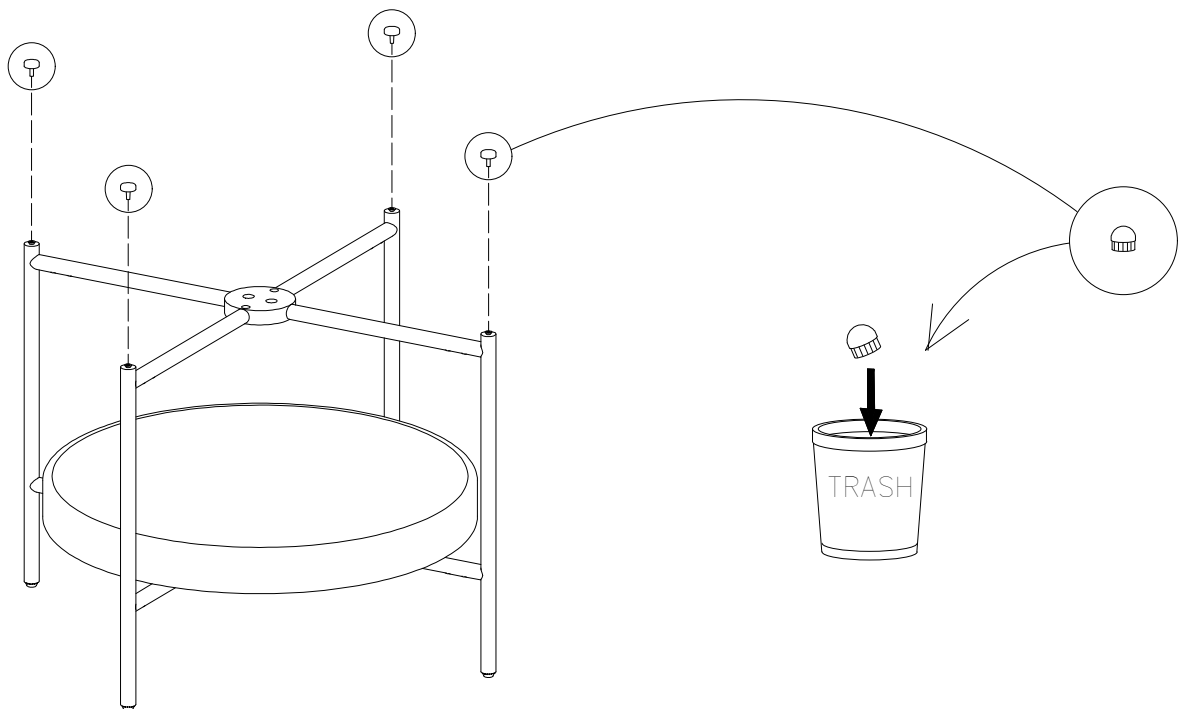

FIG. 8

Step 1 50 %  
Step 2 100 %

  
C x 4

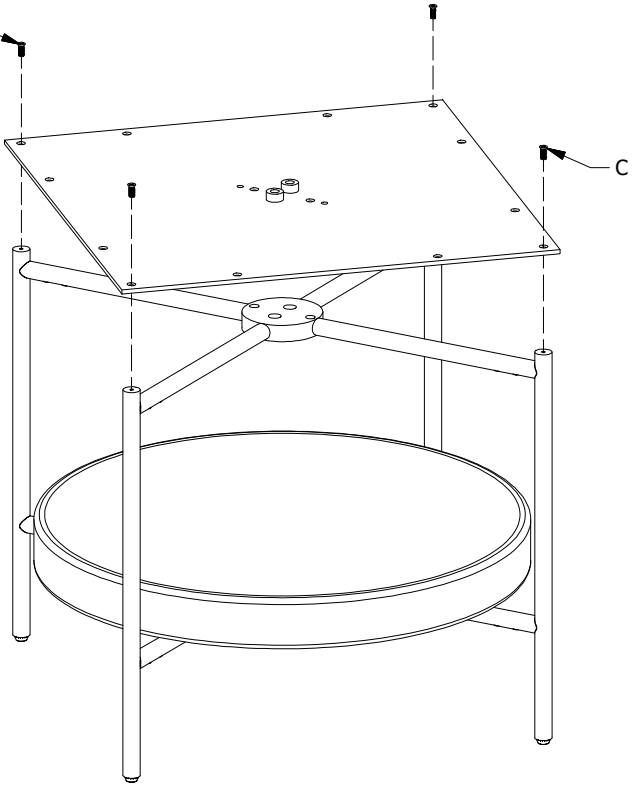
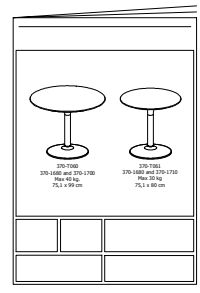
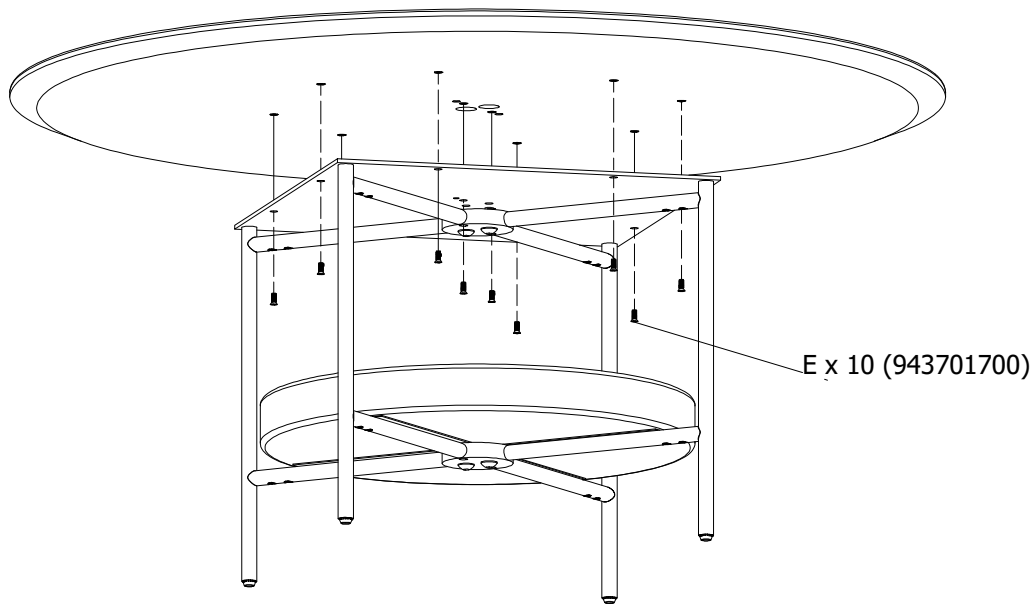

FIG. 9



- DK Ved reklamation oplyses følgende:
- D Im Reklamationsfall, bitte folgendes erläutern:
- US In case of claims, please state the following:
- F En cas de réclamation, veuillez indiquer:
- NL Bij service volgene mededelen
- E En caso de reclamación, indicar lo siguiente:
- P No caso de reclamação, por favor indique o seguinte:
- JP お気づきの点等ございましたら、以下の点をお知らせください。

Example!

